



Your easy way to space.



Space-Friendly™

# Active GNSS Patch Antenna Module

# piPATCH-AllBand

## Product Datasheet

Rev. A/2026

Intended to cover all **Satellite GNSS** needs.

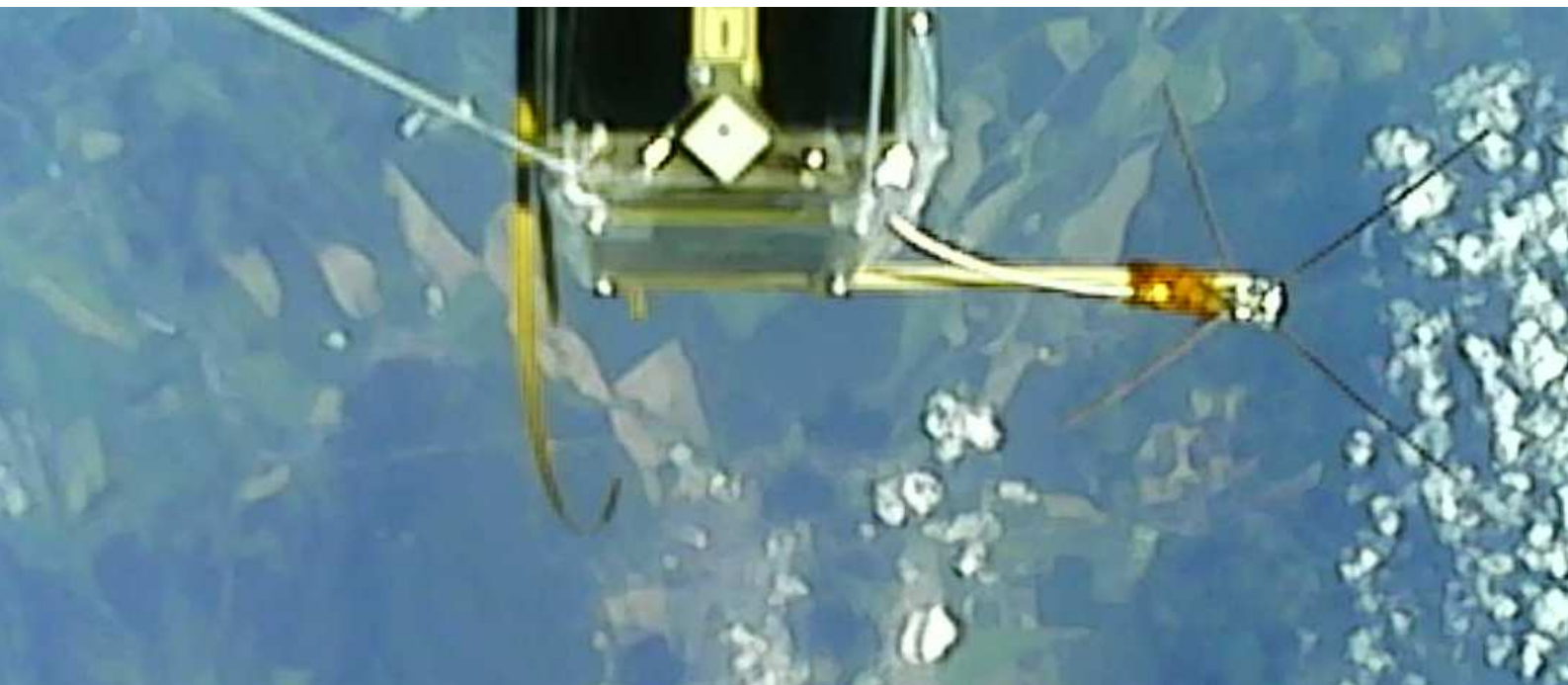

## PRODUCT DATA SHEET

## piPATCH-AllBand

### FEATURES – Flight Model

- Active GNSS antenna for CubeSats & Microsats
- GPS L1 49-51+ dBc-Hz SNR
- GPS L2 45-50+ dBc-Hz SNR
- GPS L5 45-50+ dBc-Hz SNR
- GLONASS G1 45-53+ dBc-Hz SNR
- GLONASS G2 45-50+ dBc-Hz SNR
- GLONASS G3 45-50+ dBc-Hz SNR
- Galileo E1 48-51+ dBc-Hz SNR
- Galileo E5a 48-51+ dBc-Hz SNR
- Galileo E5b 45-48+ dBc-Hz SNR
- Galileo E6 42-45+ dBc-Hz SNR
- BeiDou B1 45-48+ dBc-Hz SNR
- BeiDou B2a 45-48+ dBc-Hz SNR
- BeiDou B2b 45-48+ dBc-Hz SNR
- Power consumption  
30 mA (typical), 3.3 V @ 25°C
- 2.7 to 5.5V power supply, 3.3 V nominal
- Large groundplane insulated from Structure, AC-coupled to GND potential
- Lower band and Upper band gains: +20dB
- ESD Protection and DC Plasma Discharger
- Mass 133 grams
- Dimensions 98x82.6x13.5/-8 mm
- Wide temperature range  
-40°C to +85°C
- Connector  
MCX-F, (both Signal + Power)  
Straight (Right-angle on request)
- FR-4, 4-layers PCB
- Dual frequency SAW filters, LNAs
- Patch Epoxy-fixed (3M Ultra Low Outgassing)
- Double-sided Kapton® fix below Patch
- 60/40 Tin-Lead used (prevent tin whiskers)

### FEATURES – Engineering Model

- Active GNSS antenna for CubeSats & Microsats
- RF and DC characteristics of the Flight Model
- Red Remove Before Flight finish
- Mechanical outline fitting the Flat Sat design and AIT/AIV activities requirements
- Not intended for spaceflight/vacuum environment

### APPLICATIONS

- CubeSats, Microsatellites
- Centimeter Level accuracy GNSS receivers
- Satellite Projects using multi-constellation navigation/PVT experiments
- High precision GNSS systems with multichannel GNSS receivers
- Combined GPS, Galileo, GLONASS, BeiDou supportive GNSS systems RF signal source antenna



Fig. 1 piPATCH-AllBand/FM Patch Antenna Flight Model.

### GENERAL DESCRIPTION

The piPATCH-AllBand is the World's First Space-Friendly™ All Band Active GNSS Antenna module specially designed to provide strong signal for majority of GNSS navigation systems reception in space. Two wideband RF chains are separately equipped by the SAW filters and Low Noise Amplifiers (LNAs), matched together with 50x50 mm Patch antenna and large ground plane, DC-insulated from the mounting structure and AC-coupled to enhance the RF groundplane using the CubeSat structural rails.

Easy-to-use MCX-Female signal and power interface provides compact solution for all kind of projects where strong GNSS signal reception with enough margins is required.

The module can be easily mounted to the satellite structure using four M3 flat head screws.

The used chemistry, Kapton® based patch antenna fixture, Sn/Pb tin-lead soldering compound (non-RoHS) and FR4 used for the Flight Model baseplate brings the best possible outgassing performance in vacuum environment of space.

The antenna is fully electrically compatible with majority of 3.3 - 5V<sub>DC</sub> GNSS receivers equipped with active bias over RF coaxial input.

The Engineering Model with red Remove Before Flight finish is available for satellite development, flatsat design and AIT/AIV activities.

**TABLE OF CONTENTS**

APPLICATIONS.....	2	DIMENSIONS .....	3
GENERAL DESCRIPTION.....	2	APPLICATION NOTES & RECOMMENDATIONS.....	4
TABLE OF CONTENTS .....	3	EXPORT CONTROL.....	6
ABSOLUTE MAXIMUM RATINGS .....	3	DISCLAIMER.....	7

**ABSOLUTE MAXIMUM RATINGS**

RF $V_{IN}$ to GND .....	-0.3 V to ( $\leq 7$ V max)	Operating Temperature Range:.....	-40°C to +85°C
Chassis to GND Potential .....	+/- 50 V max	Storage Temperature Range:.....	-55°C to +100°C
DC Input Current: $I_I$ at $V_I < 0$ V or $V_I > V_{DD}$ .....	40 mA		

**NOTE:** Stresses beyond those listed under “Absolute Maximum Ratings” may cause permanent damage to the device. These are stress ratings only, and functional operation of the device at these or any other conditions beyond those indicated under specification conditions is not implied. Exposure to absolute maximum rated conditions for extended periods may affect device reliability. Voltage values are with respect to system ground terminal. The manufacturer reserves all rights to decline the responsibility for any damage caused by improper using of the piPATCH-AllBand product.



**CAUTION:** *The antenna mounting holes are DC-insulated from the RF coaxial connector GND potential acting as a power source return wire in order to prevent the grounding loops between the antenna, receiver, onboard power supply and satellite mounting wall (if conductive). Internal active electronic circuits are capacitively AC-coupled to the antenna groundplane to improve the antenna RF performance. Keep the chassis grounding in mind when designing the satellite power system to prevent the charge build-up in case the chassis is not grounded and the satellite mounting wall is not conductive or dissipatively-wise not matched to discharge the charge build-up in the plasma environment of space. Always disconnect the power before start to change the antenna electrical/mechanical setup. Overloading over the Absolute maximum ratings may affect device reliability, damage the power source device and void the product warranty.*

**DIMENSIONS**

The dual band stacked ceramic patch antenna is mounted on top of the main four layer PCB with outer dimensions of 98x82.6 mm, extending the module height from surface by up to 8 mm. As a standard, the piPATCH-AllBand antenna is equipped with the MCX-Female straight, connector. Right angle is on request.

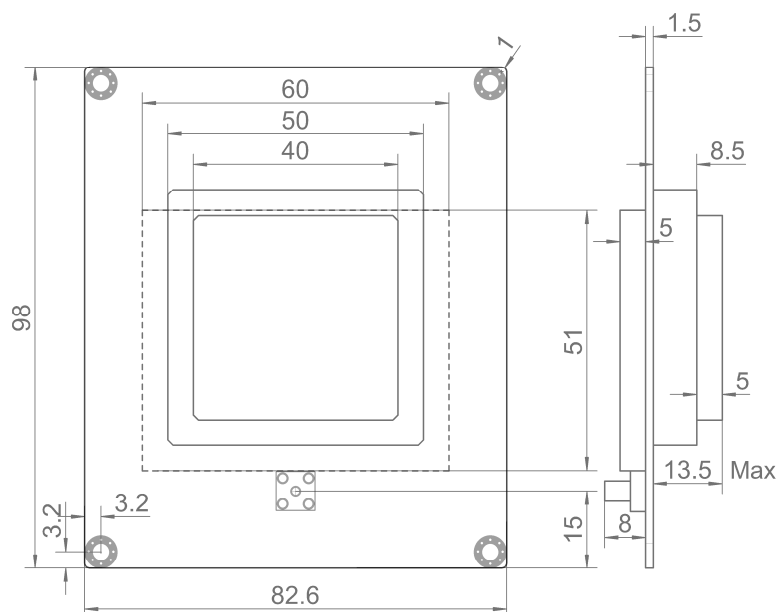

**Fig. 2 piPATCH-AllBand Dimensions drawing in millimeters. Detailed STEP file available for download.**

Tab.: 1 The piPATCH-AllBand MCX-F Connector Description.

Pin	Name	I/O, Power or Do Not Connect	Description
Shield	GND	Power	<b>System ground.</b> Must be connected to receiver ground potential. This signal is internally connected to the inner ground plane and patch antenna tap.
Center	VDD	Power	<b>Positive system power input.</b> Positive power supply input and RF signal output.

**ENGINEERING MODEL**

To test the GNSS system aboard the satellite prototype or engineering / development / qualification model, the Engineering Model grade with identical electrical and RF properties is available. The red Remove Before Flight finish with respective label reminds the user to replace the unit with the Flight Model grade unit suitable for the environment of space. Photo of the piPATCH-AllBand/EM unit is depicted in Fig. 3.



Fig. 3 Engineering Model of the piPATCH-AllBand unit with red Remove Before Flight finish.

**APPLICATION NOTES & RECOMMENDATIONS**

**EMC CONSIDERATIONS**

As the size of the small satellites imply the high level of integration of different electronic devices (switch mode power supplies, high speed digital electronics, pulse-width modulated electromagnetic actuators, etc.) into a limited satellite structure volume containing potential sources of disturbing signals, the electromagnetic susceptibility and compatibility is critical for implementation of any subsystems sensitive to electromagnetic radiation.

Proper ground planes and PCB design rules minimizing the radiated and conducted emissions shall be applied within the whole small satellite structure, including custom payloads, conventional (Communication and Data Handling, Power Supply and Power Distribution, Onboard Computer, Attitude Determination and Control) and third party electronic subsystems. The small satellite electronics should be properly designed to not disturb the GNSS receiver input frequency band with harmonic frequencies falling to the GPS L1, GPS L2, GPS L3, GLONASS G1, GLONASS G2, GLONASS G3, Galileo E1, Galileo E5a, Galileo E5b, Galileo E6, BeiDou B1, BeiDou B2a, BeiDou B2b frequency bands respectively.



**NOTE:** The  $C/N_0$  parameters (Signal-to-Noise Ratios) provided in GNSS receiver output NMEA sentences can be exploited as a diagnosis tool if the EMC issues affect the reception capability. **Always observe the  $C/N_0$  levels and switch On/Off each electronic subsystem to identify the potential source of the disturbance if needed, using (best possible) open-sky signal quality.** Typical terrestrial SNR readings for close-Zenith (high elevation) satellites are as follows: GPS L1 **49-51+** dBc-Hz, GPS L2 **45-50+** dBc-Hz, GPS L5 **45-50+** dBc-Hz, GLONASS G1 **45-53+** dBc-Hz, GLONASS G2 **45-50+** dBc-Hz, GLONASS G3 **45-50+** dBc-Hz, Galileo E1 **48-51+** dBc-Hz, Galileo E5a **48-51+** dBc-Hz, Galileo E5b **45-48+** dBc-Hz, Galileo E6 **42-45+** dBc-Hz, BeiDou B1 **45-48+** dBc-Hz, BeiDou B2a **45-48+** dBc-Hz, BeiDou B2b **45-48+** dBc-Hz. In case significantly lower SNR readings are detected during the RF test, it is recommended to review the whole RF/GNSS/satellite setup.

**ANTENNA LOCATION**

Special care should be taken to the interference with the small satellite communication or power subsystem, as an active electronic device radiating the high power electromagnetic waves. The manufacturer recommends installing the GNSS antenna as far from the (transmitting) communication antennas as possible. The RF coaxial cable (harness) between the antenna and the receiver may also pick up harmful interference along the path inside of the satellite body. **Be sure to test** the target small satellite subsystems against affecting the performance of the GNSS receiver under all satellite operation conditions.

Keep in mind the receiver may be sensitive to harmonics of the downlink (transmitter) frequency (i.e. 1178-1620 MHz /9, /8, /7, /6, /5 /4, /3,/2, etc.) or uplink receiver spurious emissions, local MPPT EMC radiation, magnetorquer PWM EMC radiation, etc. **It is highly recommended to perform full functional test on the flight or flight-representative satellite model to ensure the EMC compatibility.**

In order to maintain and/or improve the antenna radiation pattern, gain, efficiency and performance, it is **recommended to mount** the antenna **in the centre, on top of a flat and conductive surface** with thickness of **at least 0.2 mm or thicker** (L-band frequency RF penetration depth for typical metallic materials of satellite walls) in order to expand the basic antenna footprint size (98×82.6 mm). The mounting plate size is not necessary to be larger than ~190 mm in diameter (approximate L-band GNSS wavelength). If smaller, the antenna radiation pattern shall be studied further and checked/verified to conform with mission/satellite pointing requirements.

**RECYCLING**

Below mentioned logo given on the goods, its packaging or inside this Quick Start Guide or other related documentation means that used electrical or electronic devices or products should not be disposed with household waste. To ensure proper disposal of the product hand it to designated collection points, where they will be accepted free of charge. Eco disposal of SkyFox Labs s.r.o. products is maintained by collective system RETELA in Czech Republic. Please recycle product and its packaging in proper way according to valid laws in country of disposal.



The **piPATCH-AllBand / Engineering Model** is RoHS compliant.



The **piPATCH-AllBand / Flight Model** is **RoHS** compliant through exemptions, contains leaded solder.



**PRODUCT SAFETY**

According to use of the product in line with this Quick Start Guide, the product is safe under normal use. The CE mark (Conformité Européenne) has been issued on this family of products. Related EC Declaration of Conformity is issued with each supply and is available online at manufacturer’s website <http://www.skyfoxlabs.com>.



## EXPORT CONTROL

Since the country of origin of this product (the Czech Republic) is a valid participating member of the Wassenaar Agreement ( <http://www.wassenaar.org> ) and agrees with the Missile Technology Control Regime ( <http://www.mtcr.info> ) and the **piPATCH-AllBand/FM (Space-grade Flight Model)**, **piPATCH-AllBand/EM (Engineering Model)** functional parameters are considered as a regulated (Dual Use) goods, the export is controlled and needs special Export License approved by the Ministry of Industry and Trade of the Czech Republic (the local control entity), if exported outside EU-member states territory. The request for the Export License has to be submitted by the manufacturer to the local control entity, based on the binding order, including all the information as: the characteristics of goods, target country (territory), detailed end-user and target application information, etc.

## DISCLAIMER

THIS DEVICE HAS BEEN DEVELOPED WITH IDEA TO SUPPORT THE SMALL SATELLITE COMMUNITY EFFORT IN SPACE RELATED RESEARCH, ENGINEERING AND PEACEFUL CONQUEST OF SPACE. THE MANUFACTURER RESERVES ALL RIGHTS TO DECLINE THE ORDER OF THIS PRODUCT OR PROVIDE ANY FURTHER INFORMATION TO END USERS ASSUMING TO VIOLATE ANY LOCAL OR GLOBAL NATIONAL LAWS BY THIS DEVICE OR INFORMATION MENTIONED IN THIS AND RELATED DOCUMENTS. MANUFACTURER DOES NOT ASSUME ANY LIABILITY ARISING OUT OF THE APPLICATION OR USE OF THIS PRODUCT OR CIRCUIT DESCRIBED HEREIN; NEITHER DOES IT CONVEY ANY LICENSE UNDER ITS PATENT RIGHTS, NOR THE RIGHTS OF OTHERS. MANUFACTURER RESERVES THE RIGHT TO MAKE CHANGES OF THIS PRODUCT DATASHEET WITHOUT FURTHER NOTICE. THE UNIT MUST NOT BE USED IN ANY SAFETY-CRITICAL APPLICATION, OR MILITARY-RELATED, OR BY ARMED FORCES, OR BY POLICE GUARDS, OR IN NUCLEAR FACILITIES, OR IN RELATION TO OIL AND GAS MINING, ON LAUNCHERS, MISSILES, TARGET DRONES, WEAPONS OF MASS DESTRUCTION, OR GOVERNMENTAL END USE OR END USER. SAFETY-CRITICAL SYSTEMS ARE THOSE SYSTEMS WHOSE FAILURE COULD RESULT IN LOSS OF LIFE, SIGNIFICANT PROPERTY DAMAGE OR DAMAGE TO THE ENVIRONMENT. THE LIST CONTAINS MOST IMPORTANT AREAS OF PROHIBITED USE AND IS NOT COMPLETE. FOR MORE DETAILS, PLEASE CONTACT FACTORY.



Prague, Czech Republic

© 2014-2026 SkyFox Labs, All rights reserved.