



Your easy way to space.



Space-Friendly™
PocketQube ADS-B System
pqADS-B/FM

Product Datasheet

Rev. A/2017

Intended to **track Aircrafts from Space.**

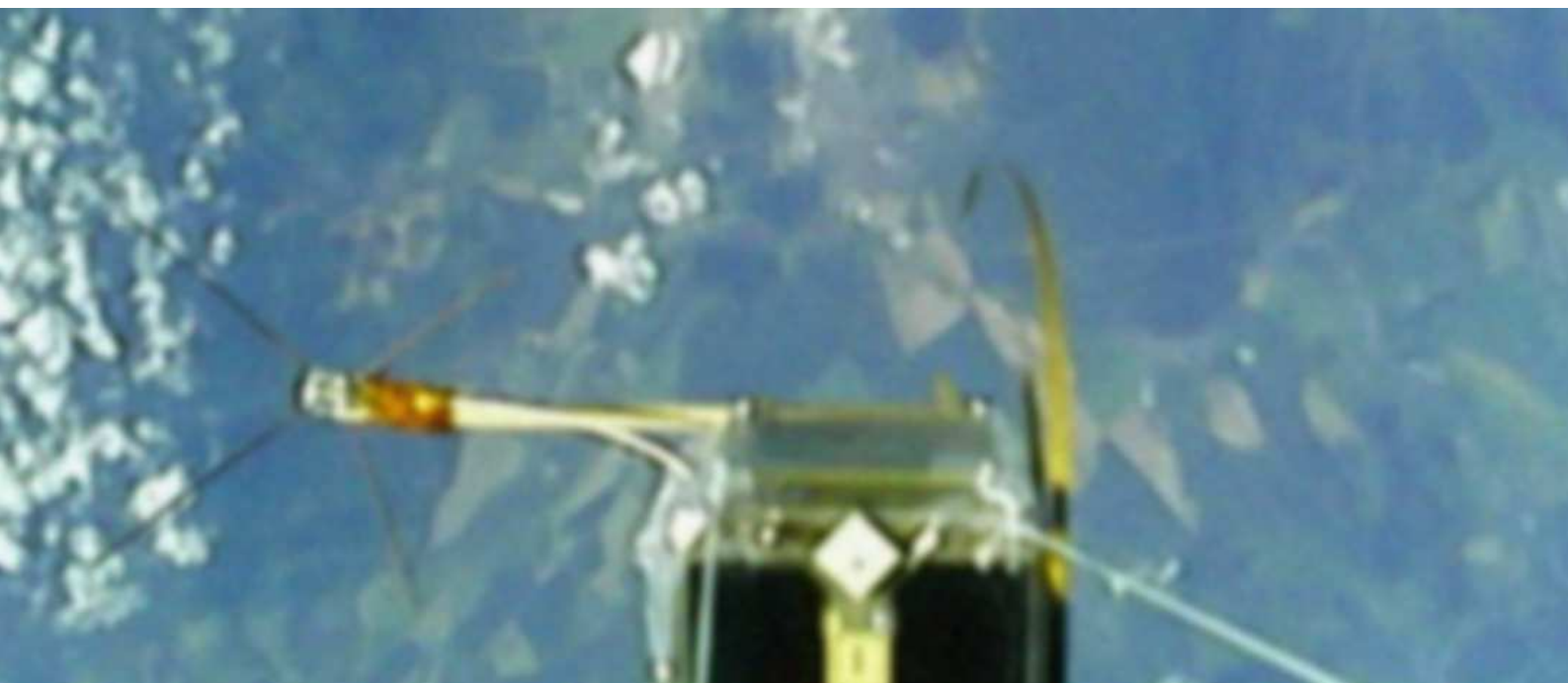

PRODUCT DATA SHEET

pqADS-B/FM

FEATURES

- Realtime Aircraft Surveillance for Space Stations
- PocketQube ADS-B System with No Deployables
- Fully functional Passive Radar for Aircraft tracking
- Automatic Dependent Surveillance – Broadcast (ADS-B) Receiver, Mode-S 1090ES
- 1090 MHz L-band Zero-IF receiver
- 112bit Extended Squitters
- Civil Downlink Format 17 (DF17) implicit output
- Highly Sensitive, Ultra Low Power, World's Lowest PocketQube Profile
- Up to 1800 km slant range
- Embedded RHCP Patch Antenna system
- Intended to LEO up to $h = 400+$ km
- Squitter Filters, CRC calculation
- PocketQube standard Compatible
- Ideal for Z+/- mount
- Mega-Constellation Ready! product
- Easy-to-Implement Data Interface
UART 230400-8-N-1, 3V3-CMOS levels
- Allow Nonstop Operation with conventional
1U CubeSat power budget
- 2.7 to 3.6V Power supply
- Power consumption
150 mW (typical), 3.3 V @ 25°C
- Velocity
0 up to 9 km/s (Flight Model)
- Startup time less than 3 seconds (typical)
- Protocols
ASCII output (standard)
HEX or Binary (on request)
- Ultra Low Profile and Dimensions
Very compact 50×50×12.5 mm
- Wide temperature range
-40°C to +85°C
- Connectors
PicoBlade™ 6P connector
doubled (+/- Power and Data signals)
- Low mass 55 grams

APPLICATIONS

- Nonstop Aircraft tracking on Small Satellites
- Aircraft Search & Rescue (SAR) Node
- Airlines / Governmental Megaconstellations
- Air Traffic Control (ATC) Management
- Limited Power Budget Space Projects
- Stratospheric, Meteorological, Scientific Balloons

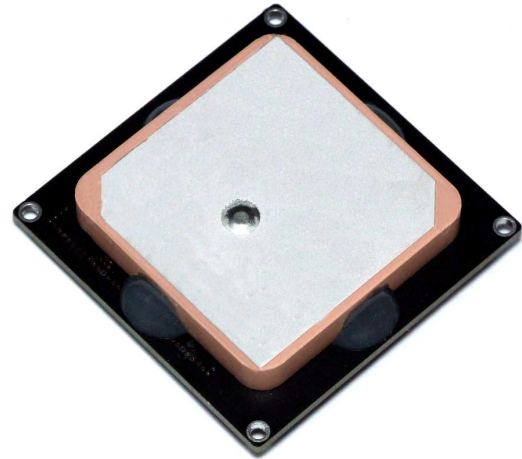

Fig. 1 Ultra Low Profile PocketQube ADS-B System, Flight Model.

GENERAL DESCRIPTION

The pqADS-B/Flight Model is the World's First Space-Friendly™ Automatic Dependent Surveillance–Broadcast or ADS-B Extended Squitter, Mode-S Passive Radar Receiver System with No Deployables, Ultra Low Profile and Power requirements intended for PocketQubes. With integrated RHCP patch antenna the product is intended to track Aircrafts from satellites in Low Earth Orbit (LEO), High Altitude Balloons (HAB) or Unmanned Aerial Vehicles (UAVs) with limited power and mass budgets.

It requires only 10 % of power in comparison with conventional space-grade ADS-B receivers allowing permanent data output.

Easy-to-use UART serial data interface output providing standardized ASCII sentences together with external ADS-B antenna provides a smart standalone solution for all kind of Space-grade or terrestrial projects where the precise Aircraft position, type, velocity, direction or ICAO/airliner information is required.

The unit is interfaced with power supply and data output using single six pin PicoBlade™ connector with redundant pins.

Very low mass and dimensions fits perfectly with all kind of space-demanding projects.

The Flight Model is assembled by ESA certified personnel.

TABLE OF CONTENTS

APPLICATIONS.....	2	PROTOCOLS	6
GENERAL DESCRIPTION.....	2	OUTPUT DATA DESCRIPTION	6
TABLE OF CONTENTS	3	ANTENNA	7
ABSOLUTE MAXIMUM RATINGS	3	APPLICATION NOTES & RECOMMENDATIONS.....	8
PARAMETRIC SPECIFICATION.....	3	QUALITY ASSURANCE	8
CONNECTORS DESCRIPTION	4	EXPORT CONTROL.....	9
FUNCTIONAL BLOCK DIAGRAM	4	DISCLAIMER	10
THEORY OF OPERATION.....	5		

ABSOLUTE MAXIMUM RATINGS

V_{DD} to GND.....	-0.3 V to +4.2 V	Other Pins to GND:.....	-0.3 V to +(V _{DD} +0.3) V
DC Input Voltage: V_I	-0.3 V to $V_{DD} + 0.3$ V (≤ 4.2 V max.)	Maximum RF Input Power:.....	+15 dBm
DC Output Voltage: V_O	-0.3 V to $V_{DD} + 0.3$ V (≤ 4.2 V max.)		
DC Input Current: I_I at $V_I < 0$ V or $V_I > V_{DD}$	± 20 mA	Operating Temperature Range:.....	-40°C to +85°C
DC Output Current: I_O at $V_O < 0$ V or $V_O > V_{DD}$	± 20 mA	Storage Temperature Range:.....	-45°C to +105°C

NOTE: Stresses beyond those listed under “Absolute Maximum Ratings” may cause permanent damage to the device. These are stress ratings only, and functional operation of the device at these or any other conditions beyond those indicated under specification conditions is not implied. Exposure to absolute maximum rated conditions for extended periods may affect device reliability. Voltage values are with respect to system ground terminal.

PARAMETRIC SPECIFICATION

$T_A = -40^\circ\text{C}$ to $+85^\circ\text{C}$, $V_{DD} = 3.3$ V, Integrated RHCP patch antenna used, unless otherwise noted.

Parameter	Symbol	Min	Typ	Max	Units	Notes/Conditions
Operating Supply Voltage	V_{DD}	2.7	3.3	3.6	V	
Operating Supply Current	I_b		45	46	mA	Continuous DC current consumption during nominal operations.
Operating Power Consumption	$P_{Oper-Pass}$		150		mW	
Operating Frequency	f_{RFIN}		1090		MHz	1090ES, L-band
RF Bandwidth	BW		15		MHz	
Operating Velocity	V	0		9	km/s	
Time-to-First-Frame	t_{TFF}			3	s	The pqADS-B Start-up time.
Slant Range	d		900	1800	km	Depending on the ADS-B Out transponder output power. Valid for both Vertical and Horizontal antenna orientation.
Output Data Framerate	FR	0		2000	fpm	Framerate given by DF17 frames filtering and provided at 230400 bps output bitrate. Framerate is limited by amount of Downlink Format frames selected and output bitrate.
Output Data Bitrate	Bd	9600	230400	1250000	bps	Bitrate settings are uploaded and fixed during manufacturing process. No post-manufacturing settings possible.
Output Frame Data Quality	DQ	100			%	As a standard, only CRC-checked Downlink Format 17 frames are provided. Most civil airliners uses ADS-B 1090ES frames to broadcast the most useful and detailed data in this frame type. 100% of all output data frames are valid, based on internal software-defined Cyclic redundancy check.

CONNECTORS DESCRIPTION

The pqADS-B/FM receiver is connected to the target system via standardized MOLEX 6 pin connector. Each pin, its function and direction or manner of use is indicated in the Tab.: 1 below. The connector location within the Flight Model is displayed in Fig. 2.

Tab.: 1 **The pqADS-B/Flight Model Pin Description**, NOTE: Minimum required interface pins are highlighted.

Pin	Name	Input, Output, Power	Description
1	VDD	Power	Positive system power input. Positive power supply input, connect to +3.3 V with respect to GND system ground pins.
2			
3	TXD	Output	ADS-B Receiver serial data output. ASCII sentences are present on this pin. Data is provided by standard UART serial transfer at a rate of 230400 bps, no parity, 8 data bits, 1 stop bit. LVCMOS compatible signaling.
4			
5	GND	Power	System ground. Must be connected to ground potential. This pin may be internally connected to standoff pads. Solder GND-1, GND-2, GND-3 or GND-4 to connect ground potential to chassis pads.
6			

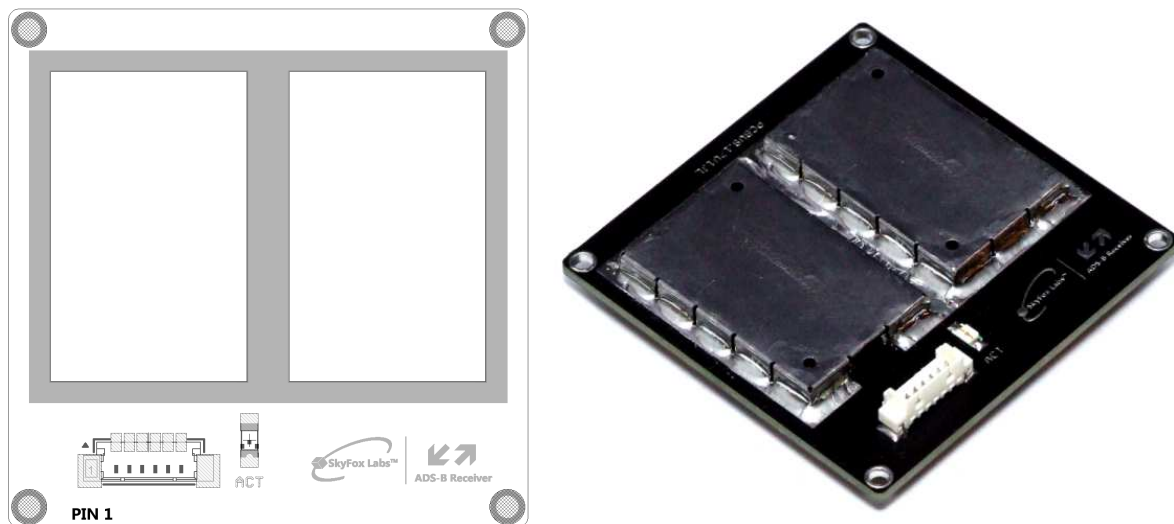

Fig. 2 **The pqADS-B/FM Connector pinout and LED location**. NOTE: The pqADS-B/FM is displayed from the BOTTOM side. The SMD mount connector type is MOLEX 53398-0671 with 1.25mm pitch. Detailed dimensions drawing is available online as STEP model.

FUNCTIONAL BLOCK DIAGRAM

The key functional blocks of the pqADS-B/FM are described in Fig. 3. The system consists of the high gain Patch antenna, Low Noise Amplifier (LNA), SAW Filter, Down Converter to Zero-IF and High speed baseband data processing core. The design of the front-end guarantees excellent noise figure and ensure high suppression of the out of band signals. The frame decoder, downlink format filter, CRC calculation and serialization is performed in high speed digital core. Output ASCII sentences are provided via UART interface. The pqADS-B/FM receiver is realized on 4-layers PCB including two power planes to maximally suppress the noise of analogue and digital circuits and protect the receiver circuits against interference from the other electronics (EMC susceptibility). Frame transmission indication LED is used for quick check of the receiver's activity. DC discharge attenuation and ESD protection is applied on the RF connector input.

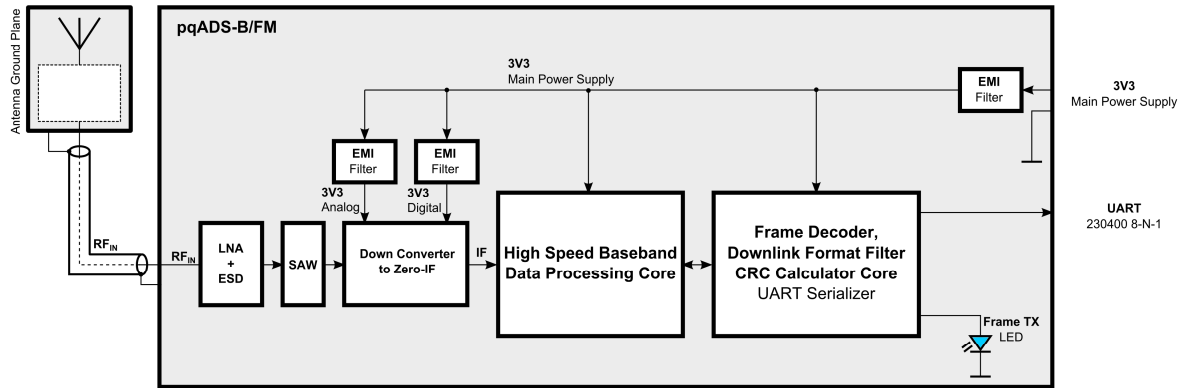

Fig. 3 The pqADS-B Receiver Block Diagram.

THEORY OF OPERATION

The pqADS-B/FM unit is the standalone single channel zero-IF receiver processing freely available frame transmissions of the Aircrafts' Mode-S Automatic Dependent Surveillance–Broadcast or ADS-B Extended Squitter, Mode-S Passive Radar working on 1090 MHz frequency band. Signals are broadcasted by flying or fly-ready aircraft transponders upon terrestrial Air Traffic Control (ATC) interrogations broadcasted at 1030 MHz. Concurrent in-flight transponders interrogations occurs also by line-of-sight airplanes in the air.

Data processing core and RF signal chain supports 1090ES transport protocol only. Interrogation reception on 1030 MHz or 978 MHz Universal Access Transceiver (UAT) transport protocol are not implemented.

Aircraft Flight Management System (FMS) produces data which are then stored in Binary Data Store or so-called BDS registers. This aircraft's digital memory space is updated according to actual in-flight values as a database source for Mode-S interrogation replies. Moreover a total of 112 bits long Mode-S Extended Squitter frames transmitted at a rate of 1 mbps contains cyclic redundant check (CRC) bytes to help control the correctness of transmitted data on receiver side.

High frequency L-band RF signal from the passive antenna is fed through the Low Noise Amplifier with ultra low Noise Figure and ESD protection blocking the DC bias and possible antenna plasma charging in space. Signal is then filtered out to clean out-of-band signals using SAW filter with as low as 2dB passband attenuation. Downconversion to zero-IF band is then performed to feed the high speed data processing core. The frame header pattern is continuously searched in digitized input signal. In case the frame initial header is correctly found in the signal, the record of following 112 bits long datagram is extracted using SkyFox Labs' developed demodulator and decoder. Zero-IF conversion together with software-defined decoder allows the receiver to perform the whole reception task using ultra low power requirement only.

On top of signal recordings the Downlink Format or data type filtering is performed and in case of Downlink Format 17, the CRC is calculated. If the calculated CRC matches the received CRC data, the serialized data output is provided on output TX pin. During the processed datagram transmission the associated SMD LED shines to indicate the receiver performance. Ultra low power LED requirement and short duty cycle allows user to remain the LED soldered even for flight conditions.

The pqADS-B receiver software-defined demodulator and data processing core allows to perform also other Downlink Format reception processing and output. However, in most cases Downlink Format 17 frames provided by civil aircrafts' broadcasts contains the most useful and most detailed data such as position, ICAO callsign, velocity, heading, etc. From this point of view, the DF17 filter has been implemented as fixed providing 100% of output datagrams to be correct.

The same frequency band (1090 MHz) is also shared with the Traffic Collision Avoidance System (TCAS), by different frequency channel spacing also due to the Distance Measuring Equipment (DME) system interrogations. Furthermore, more aircraft transponders may share the same band at a time by nature of timing-uncoordinated media access transmissions. Several transponders in the range are also broadcasting different types of frames. Certain amount of packet loss rate is thus always expected. Including the CRC filtering, the frame rate of DF17 pqADS-B/FM output data is therefore in order of 2000 sentences per minute.

PROTOCOLS

The physical communication is realized via the standard UART data interface. The baud rate is set to 230400 bps, no parity, 8 data bits, 1 stop bit. Logical levels are equal to LVCMOS (3.3V) levels as defined in JEDEC JESD8C.01 standard.

Baudrate is defined during the manufacturing process and cannot be changed later on. 230k4 baudrate is a well tested compromise between the receiver lock-out time needed to process the data transfer and slow enough to not overload upper level system with too much interrupt requests caused by UART data reception.

OUTPUT DATA DESCRIPTION

Data is provided in ASCII representation of HEX characters. Thus for example one received byte from air radio traffic represented by binary set (0b00111100), which means 60d (Decadic) and 0x3C in Hexadecimal representation is provided as two bytes - ASCII letter "3" followed by ASCII letter "C". This is to make the data reception easily readable using standard serial terminal in PC. Fully binary data output would cause non-printable characters to be shown on serial terminal (like Hyperterminal, etc.) However, fully binary data output is two times shorter than ASCII representation of course.

NOTE: Firmware modification to provide only BINARY data is possible to perform on request during manufacturing process. To make the use of the unit as much simple as possible, no settings is needed and also is not possible (no RXD pin on main interface). Thus customer shall decide which format requires in advance. Modification is provided free of charge.

Each datagram is initiated with the character "*" (star) prefix and ended with semicolon ";" and **CR + LF** (0x13h + 0x10h) suffix string.

A) ASCII Output - STANDARD:

As a standard, the pqADS-B/FM unit is delivered with firmware providing 112 bit long 1090ES datagrams of Downlink Format 17, which means the datagram contains 28 bytes of ASCII data with 1 byte prefix and 3 bytes suffix. Total of 1+28+3 = **32 bytes** are provided, with fixed length.

B) BINARY Output - ON REQUEST ONLY:

In case the Binary output is selected during the order process, the prefix and suffix characters remains the same, to keep good orientation in data stream. However, internal datagram is shorter, only 14 bytes. Total of 1 + 14 + 3 = **18 bytes** are provided, with fixed length.

pqADS-B OUTPUT SENTENCE Example

```
*8D3C54659909C8173004A132B0C5;
```

There are several freely available online resources describing how to parse the output data into dedicated BDS register's information. It is out of scope of this document to provide detailed packet content and parsing procedures.

However, for **Search and Rescue (SAR) applications**, the most valuable content is stored on byte positions shown in underlined **bold** below. **Each** received datagram provided by the pqADS-B/FM represents published unique Mode - S **Aircraft ICAO Registration Code**. From the example above is thus the ICAO code as following:

```
*8D3C54659909C8173004A132B0C5;
```

☞ Identified Aircraft ICAO Code is: **3C5465**

There is much more information provided about the aircraft flight parameters such as Aircraft Velocity, Altitude, Heading, GPS position, etc. in pqADS-B/FM data output / DF17. Above is listed only one example showing how to easily interpret the data.

ANTENNA

The pqADS-B/FM receiver system is equipped with SkyFox Labs-optimized high gain RHCP ceramic patch antenna with benefit to neglect vertical/horizontal polarization losses in orbit operations. The pqADS-B antenna uses the PocketQube Conductive structure as an extension of the basic 50x50 mm groundplane. A proper DC+AC coupling between the PocketQube structure and the pqADS-B ground potential and mounting holes must be provided to keep the pqADS-B antenna performance working nominally. An example of the antenna mount on the Z- part of the 3p PocketQube structure is depicted in Fig.4. To achieve fully symmetrical radiation pattern the opposite-to-slider panel mount is recommended. Conductive elements, parts or other obstacles elevated above the pqADS-B ceramic antenna groundplane and in its close proximity might decrease the overall system performance.

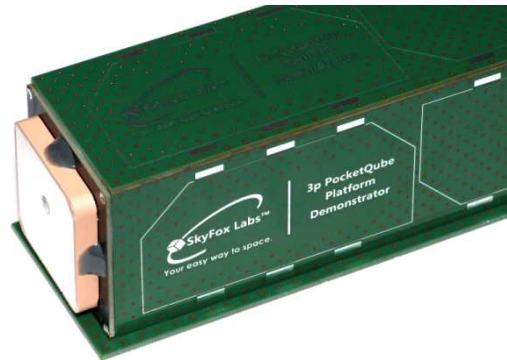

Fig. 4 Optimized pqADS-B/FM Antenna mount.

As aircrafts typically uses vertically polarized monopole antenna, their radiation pattern minimizes the power transmitted directly from Aircraft to Zenith. From this reason, it is recommended to keep the pqADS-B antenna facing slightly off the Nadir (downstream) with suitable ADCS (Attitude Determination and Control Subsystem) during orbital operations. In-flight aircraft's Angle-of-Attack (AoA) helps to increase the off-Zenith (upstream) transmitter radiation pattern angle and thus increases the datagram reception probability.

Recommended range of deviation angles-of-Nadir allowing the pqADS-B to track data is presented for two LEO altitude cases below. In Fig. 5 the average slant range of 900 km and 300km altitude (10°-80°), as well as 900km slant range and 300km altitude (31°-59°) are depicted.

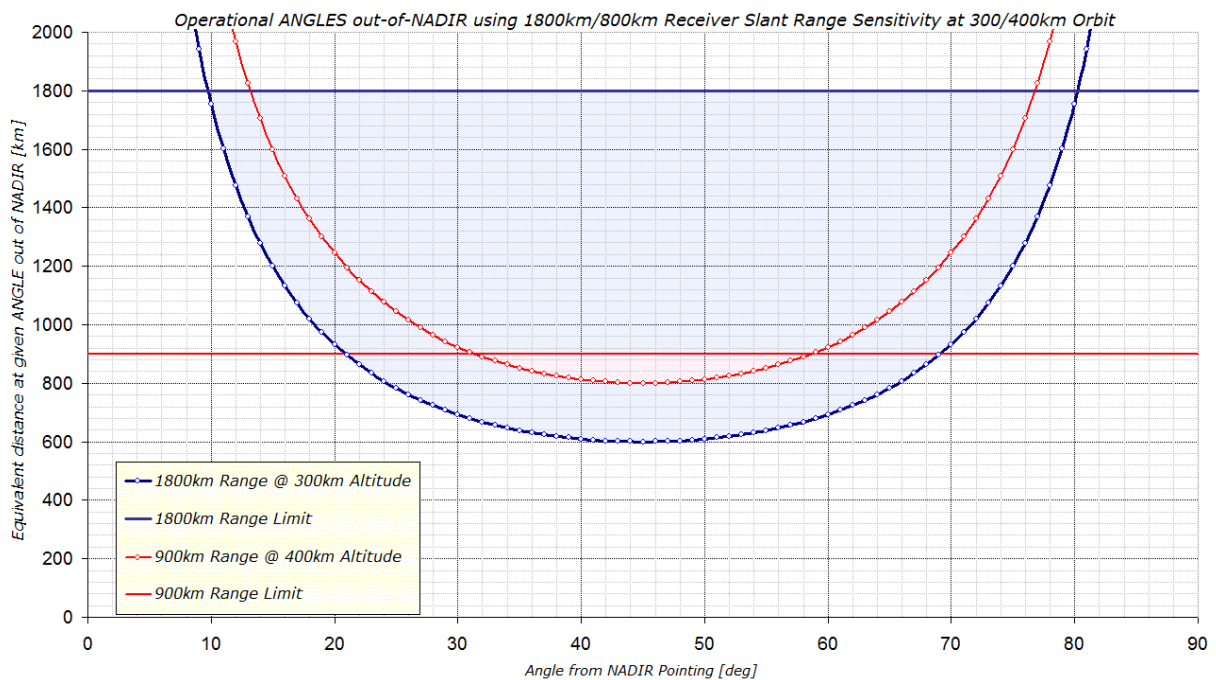

Fig. 5 Operational Angles out of NADIR for 300 and 400 km orbits.

APPLICATION NOTES & RECOMMENDATIONS

EMC CONSIDERATIONS

As the size of the small satellites imply the high level of integration of different electronic devices (switch mode power supplies, high speed digital electronics, pulse-width modulated electromagnetic actuators, etc.) into a limited satellite structure volume containing potential sources of disturbing signals, the electromagnetic susceptibility and compatibility is critical for implementation of any subsystems sensitive to electromagnetic radiation.

Proper ground planes and PCB design rules minimizing the radiated and conducted emissions shall be applied within the whole small satellite structure, including custom payloads, conventional (Communication and Data Handling, Power Supply and Power Distribution, Onboard Computer, Attitude Determination and Control) and third party electronic subsystems. The small satellite electronics should be properly designed to not disturb the ADS-B receiver input with harmonic frequencies falling to the 1090 MHz L-band.

Observe the maximum distance logged over 1 hour of daylight operations and compare it with switched On/Off electronic subsystem to identify the potential source of the disturbance if needed.

QUALITY ASSURANCE

GENERAL INFORMATION

Since the pqADS-B/FM receiver has been designed for the operation in harsh space environment as a specially featured electronic device based on Commercial Off-the-Shelf (COTS) components, the special care is taken to follow the standardized space-grade product assembly procedures, materials and components where possible (i.e. no Radiation Hardened integrated circuit are used).

MATERIALS

Components are soldered on the Space-grade 4-layers FR-4 PCB, using 60/40% (Tin/Lead) compound. Special Non-toxic Löthönig® Super Flux is used for precise soldering of the integrated circuits for its excellent soft soldering quality properties, complying with the RoHS 2002/95/EC directive. No PCB conformal coating is used on /FM and /EM products to exclude the outgassing. The volume of the gold is limited to a minimum by implementing the only gold-plated main interface connector providing excellent connection performance. The NASA approved 3M Scotch Weld Epoxy is used for critical component fixings.

Vacuum-proof electronic components from ESA and NASA-preferred space-grade vendors are used (i.e. no electrolytic capacitors) in industrial or military temperature grade, where possible.

PROCESSES

The Flight Model is hand soldered, assembled in 100.000 Class Clean Room by the ESA-certified personnel. The PCB is then cleaned using the Isopropyl Alcohol, programmed and tested. Post production burn-in screening test is performed for 96 hours under nominal operating conditions.

PACKAGING & SHIPPING

Once the pqADS-B/FM successfully passes the screening test, it is finally cleaned, optically inspected and shipped encapsulated in ESD protective packaging.

EXPORT CONTROL

Since the country of origin of this product (the Czech Republic) is a valid participating member of the Wassenaar Agreement (<http://www.wassenaar.org>) and agrees with the Missile Technology Control Regime (<http://www.mtcr.info>) and the **pqADS-B/FM (Space-grade Flight Model)** functional parameters are considered as a regulated goods, the export is controlled and needs special Export License approved by the Ministry of Industry and Trade of the Czech Republic (the local control entity). The request for the Export License has to be submitted by the manufacturer to the local control entity, based on the binding order, including all the information as: the characteristics of goods, target country (territory), detailed end-user and target application information, etc.

Manufacturer is fully prepared to support the customer with obtaining the valid Export License (if approved by the local control entity). The entity declares the typical Export License assessing period from **30 to 60 days** since the Export License Application Form delivery, implicating the respective product delivery date extension.

DISCLAIMER

THIS DEVICE HAS BEEN DEVELOPED WITH IDEA TO SUPPORT THE SMALL SATELLITE COMMUNITY EFFORT IN SPACE RELATED RESEARCH, ENGINEERING AND PEACEFUL CONQUEST OF SPACE. THE MANUFACTURER RESERVES ALL RIGHTS TO DECLINE THE ORDER OF THIS PRODUCT OR PROVIDE ANY FURTHER INFORMATION TO END USERS ASSUMING TO VIOLATE ANY LOCAL OR GLOBAL NATIONAL LAWS BY THIS DEVICE OR INFORMATION MENTIONED IN THIS AND RELATED DOCUMENTS. MANUFACTURER DOES NOT ASSUME ANY LIABILITY ARISING OUT OF THE APPLICATION OR USE OF THIS PRODUCT OR CIRCUIT DESCRIBED HEREIN; NEITHER DOES IT CONVEY ANY LICENSE UNDER ITS PATENT RIGHTS, NOR THE RIGHTS OF OTHERS. MANUFACTURER RESERVES THE RIGHT TO MAKE CHANGES OF THIS PRODUCT DATASHEET WITHOUT FURTHER NOTICE.



Prague, Czech Republic

© 2014-2017 SkyFox Labs, All rights reserved.